

## SERVICES

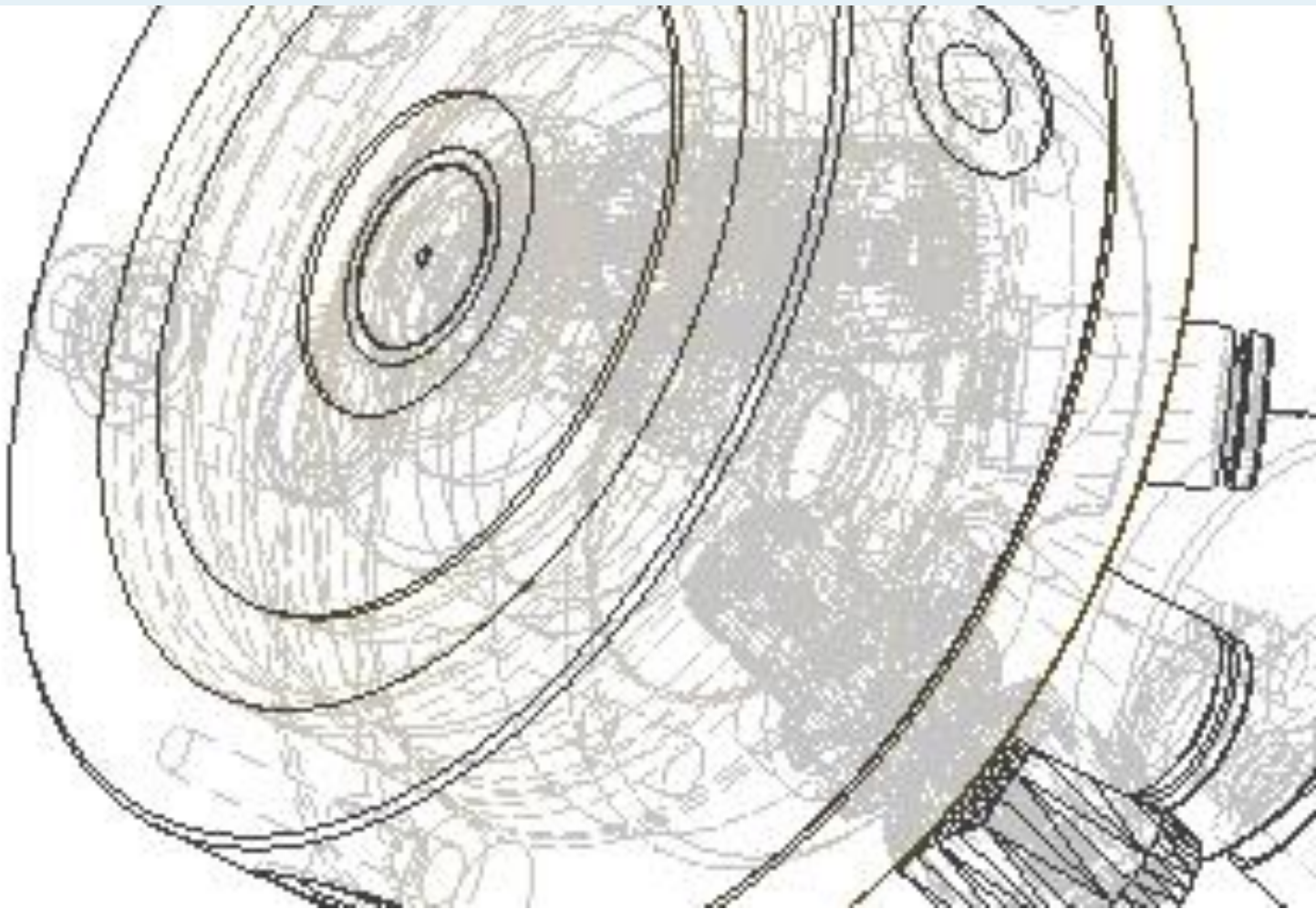

- NANOPARTICLE PRODUCTION**
- CHARACTERIZATION OF FINE PARTICLES AND NANOMATERIALS**
- AEROSOL AND SPRAY MEASUREMENTS**
- ENGINEERING OF GAS-PHASE PARTICLE PRODUCTION PROCESSES**

ParteQ offers a broad range of services related to gas-phase particle production, spanning aerosol measurements, particle characterization, contract synthesis, process development and scale-up, economic and technical process analysis, design of equipment prototypes and realization of turn-key production systems.

## Nanopowder production

We offer development and production services for nanopowders using the flame spray pyrolysis (FSP) process. Services offered range from feasibility studies to scale-up and production of nanopowder batches up to approximately 50 kg.

If you would like to have a certain material in nanopowder form or want to exploit the properties of flame-made materials, we recommend a feasibility study as starting point. Here we will first develop an appropriate precursor system, i.e. combine suitable raw materials and solvents for flame spray synthesis. Then, gram batches of nanopowder will be produced with our laboratory-scale FSP reactor. Different process conditions will be evaluated and the product materials characterized. If the material looks promising, larger nanopowder batches up to approx. 200 g can be produced.

Should you require even larger quantities or would like to evaluate industrial production of a certain nanopowder, a scale-up study can be conducted, transferring the production process from our lab-scale unit to a pilot-plant capable of producing nanoparticles at approx. 1kg/h. Different settings of process parameters will be explored and samples characterized. Typically, a scale-up study also includes an optimization of process costs.



Finally, pilot-scale production of the desired material can start, providing nanopowder batches of a few kg up to about 50 kg. Production of even larger quantities is possible through partners. Of course, you can also opt directly for a feasibility study or production on the pilot plant without going through the lab-scale feasibility.

## Particle characterization

ParteQ offers a range of characterization services for fine particles and nanomaterials. We have access to particle technology laboratories with state-of-the-art characterization equipment, allowing the analysis of materials for instance by

- Nitrogen adsorption
- X-ray diffraction
- Electron microscopy
- Thermogravimetric analysis
- Infrared spectroscopy
- UV-vis spectroscopy
- Raman spectroscopy
- Fluorescence spectroscopy



# ParteQ

Further characterization methods are available or can be arranged through a network of partners. Please contact us to discuss your characterization task. All analyses are carried out by trained personnel familiar with the equipment.

## Aerosol measurement services

ParteQ has a range of aerosol diagnostic instruments available for characterization of particle concentration and/or size inside gas-phase production processes, in the workspace or the environment. For instance, nanoparticle size distributions can be determined *in-situ* a process or in the off-gas, fine dust exposure and sprays can be monitored, all with on-line tools. We can also set up appropriate sampling and dilution stages. Most of the instruments can be purchased through ParteQ.



Furthermore, equipment for spray characterization is available. Droplet size and concentration measurements are offered. Determination of droplet size and velocity distributions with high spatial resolution by phase Doppler anemometry (PDA) and time shift measurement (SPRAYSPY) is possible, as well.

## Process engineering

Specializing on gas-phase particle synthesis, we offer process development

and optimization services, scale-up studies and the design of process equipment.

Would you like to explore the possibility of producing a material by a gas-phase process or optimize an existing process technically and economically? Do you need to scale-up an existing laboratory or small-scale production process? Does your reactor or particle collection system require a re-design? – These are typical questions that ParteQ is addressing.

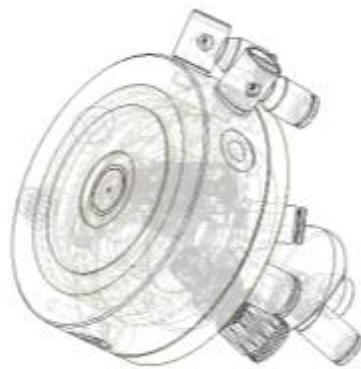

We can help with the analysis of your process, do on-line measurements or characterize product particles, conduct literature studies, develop process flow charts and P&I diagrams, select appropriate instrumentation, design a new reactor in 3D CAD, build equipment prototypes and even realize entire lab- and pilot-scale process plants with automated control systems. Do not hesitate to contact us with your special needs.

